

U1
W83628F

{Default setting}
Connected to IDESEL
R2-On R1:Off

- Revision 0.3 notes
- 1.Added optional notes (R1,R2,R3,R4)
 - 2.Added ROM decoder power-on setting register(R21)
 - 3.Modify the pin name (HS3) to (ROMCS#) and add the circuit about ROM decoder. (W83628F)
 - 4.(HS3) of W83628F has renamed (NC).



Title W83628F & W83629D FOR PCI TO ISA BRIDGE

Size	Document Number	Rev
Custom#628-1.SCH		0.3

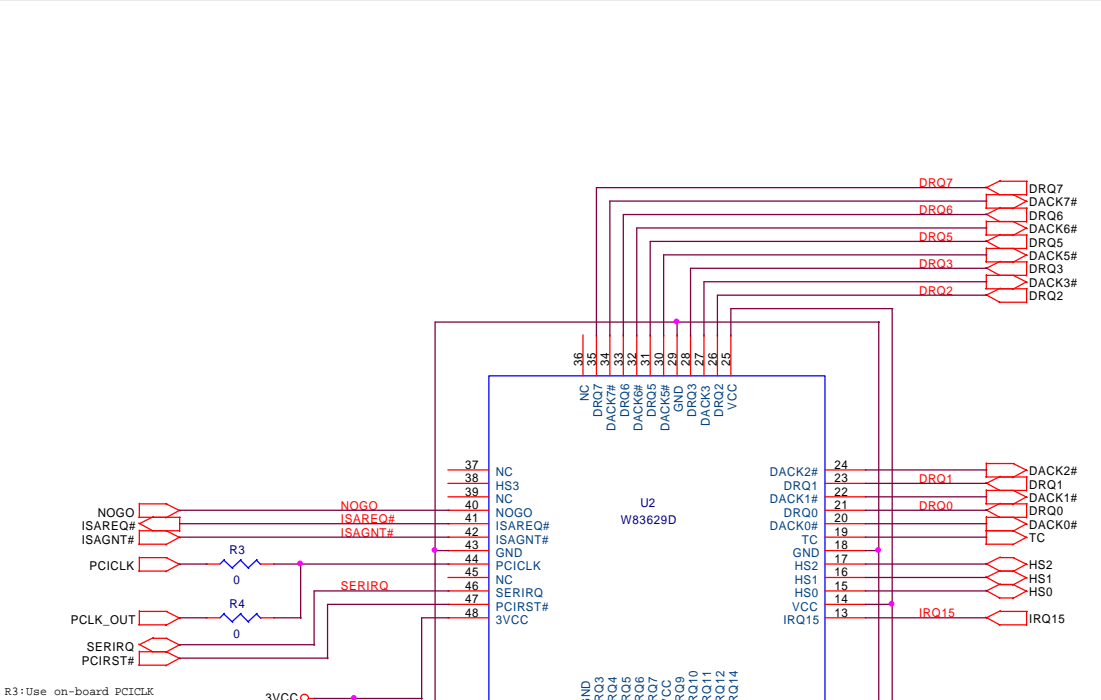

R3: Use on-board PCICLK
 R2: Use the CLK from W83628F

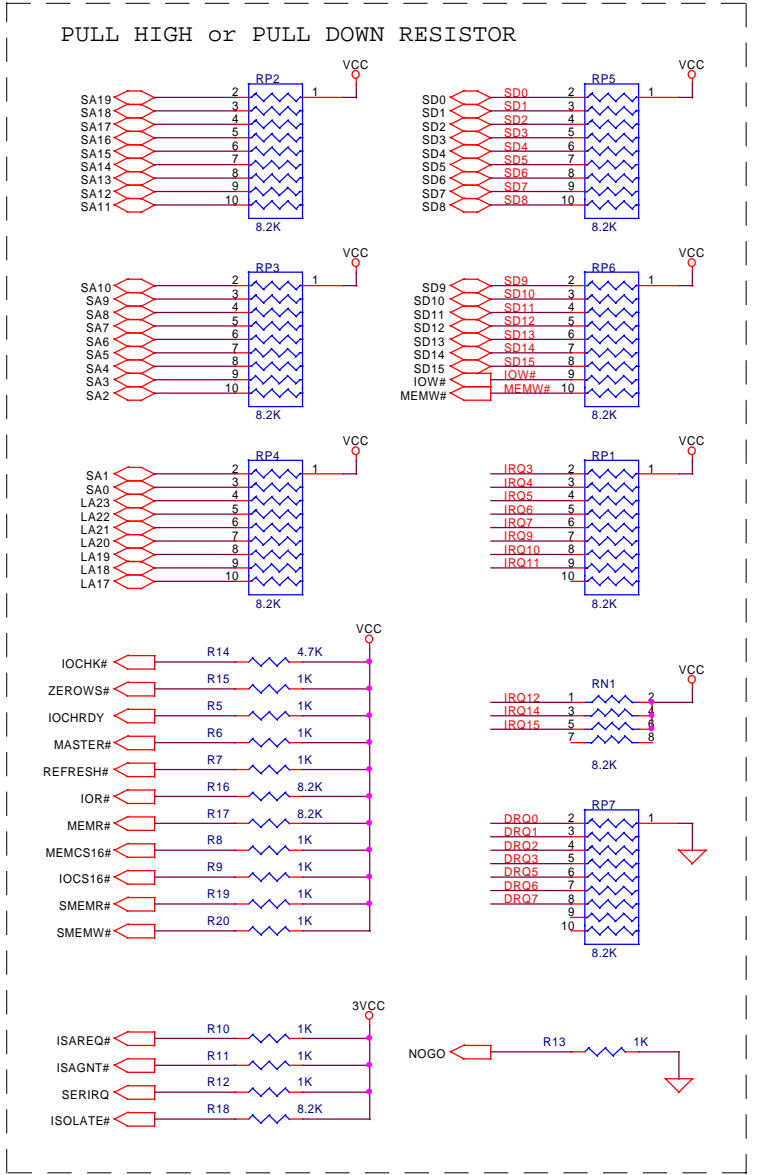
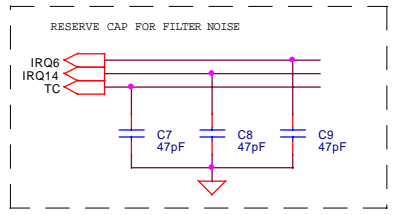
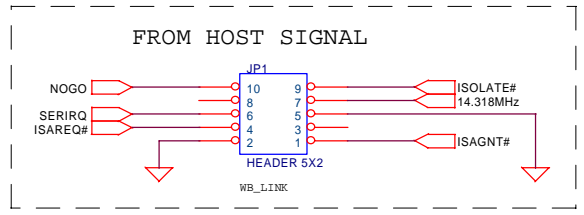

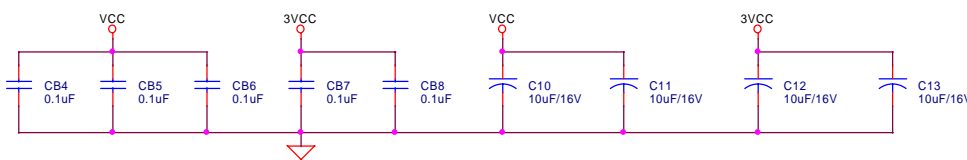
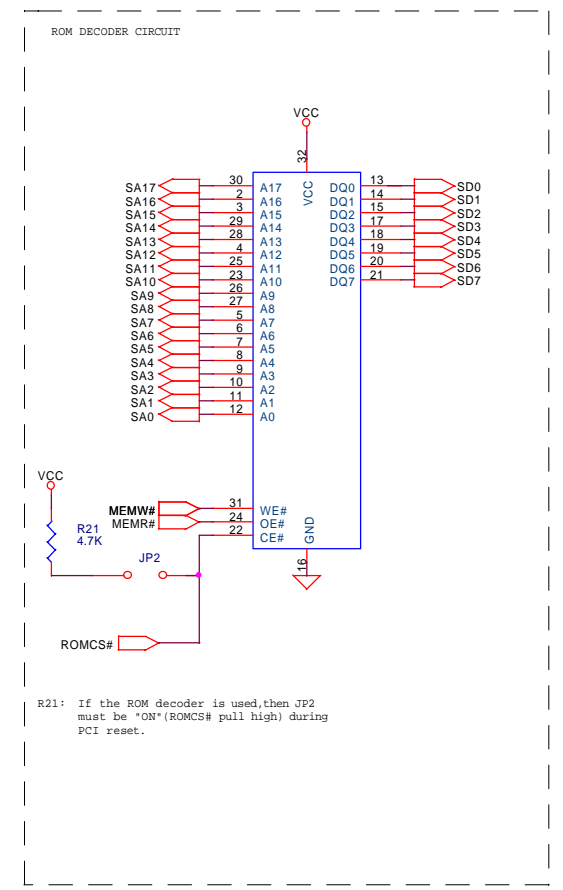
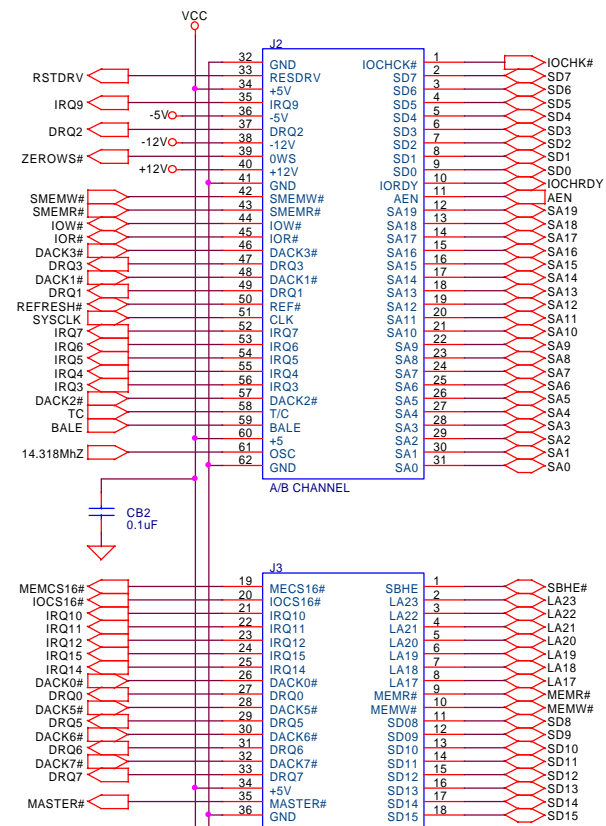
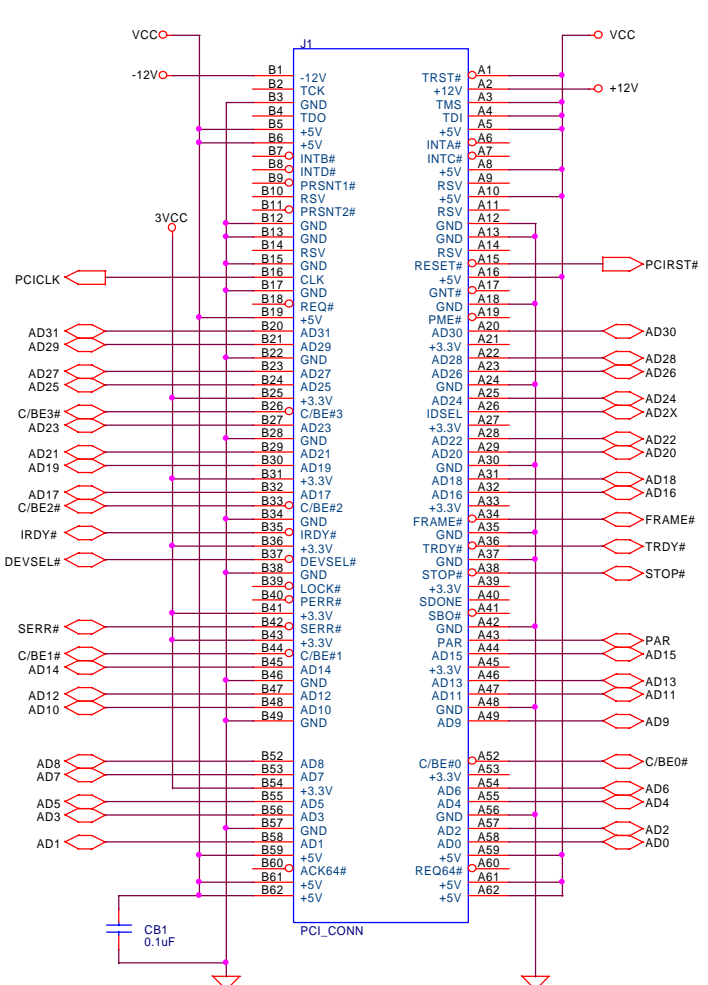

Winbond
WINBOND ELECTRONICS CORP.

Title: W83628F & W83629D FOR PCI TO ISA BRIDGE

Size	Document Number	Rev
Custom#628-3.SCH		0.3

Date: Friday, January 29, 1999 Sheet 3 of 3